

USER'S GUIDE

RP-7983/RP-7984

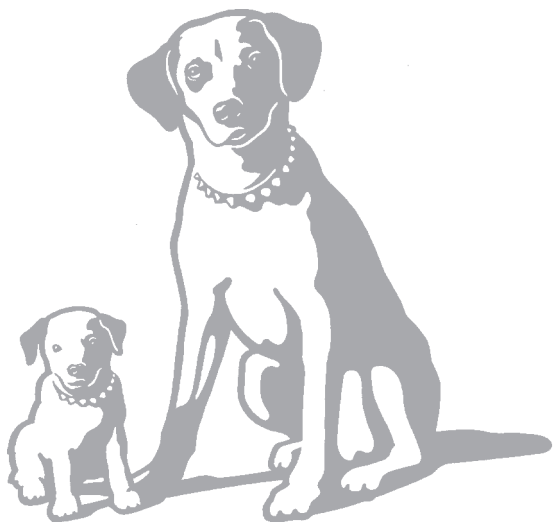

PORTABLE STEREO SYSTEM

TRF

IMPORTANT INFORMATION REQUIRED BY FEDERAL COMMUNICATIONS COMMISSION CONCERNING RADIO FREQUENCY INTERFERENCE

This device generates and uses radio frequency (RF) energy, and if not installed and used properly, this equipment may cause interference to radio and television reception.

This equipment has been type tested and found to comply with the limits for a Class B Computing Device in accordance with the specifications in Subpart J of Part 15 of FCC Rules. These rules are designed to provide reasonable protection against radio and television interference in a residential installation. However, there is no guarantee that interference will not occur in a particular installation.

If this equipment does cause interference to radio or television reception (which you can determine by turning the equipment off and on), try to correct the interference by one or more of the following measures:

- Reorient the receiving antenna (that is, the antenna for the radio or television that is "receiving" the interference).
- Move the unit away from the equipment that is receiving interference.
- Plug the unit into a different wall outlet so that the unit and the equipment receiving interference are on different branch circuits.

If these measures do not eliminate the interference, please consult your dealer or an experienced radio/television technician for additional suggestions. Also, the Federal Communications Commission has prepared a helpful booklet, "How To Identify and Resolve Radio TV Interference Problems." This booklet is available from the U.S. Government Printing Office, Washington, DC 20402. Please specify stock number 004-000-00345-4 when ordering copies

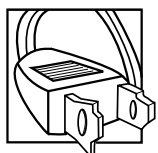

PRECAUTIONS

- **Never open the cabinet** under any circumstances. Never operate this product with the cabinet removed. Any repairs or internal adjustments should be made only by a trained service technician.

IMPORTANT BATTERY INFORMATION

- If you're not going to use your player for a month or more, be sure to remove batteries because they can leak and damage the unit.
- Dispose of batteries in the proper manner, according to federal, state, and local regulations.
- Any battery may leak electrolyte if mixed with a different battery type, if inserted incorrectly, if all batteries are not replaced at the same time, if disposed of in fire, or if an attempt is made to charge a battery not intended to be recharged.
- Discard leaky batteries immediately. Leaking batteries can cause skin burns or other personal injury.

SERVICE INFORMATION

This product should be serviced only by those specially trained in appropriate servicing techniques.

- **Do not touch the player with wet hands.** If any liquid enters the player cabinet, take the player to a trained service technician for inspection.
- **This Compact Disc Player uses a laser** to read the music on the disc. The laser mechanism corresponds to the cartridge and stylus of a traditional record player. Although this product incorporates a laser pick-up lens, it is completely safe when operated according to directions.

FOR YOUR SAFETY

The AC power plug is polarized (one blade is wider than the other) and only fits into AC power outlets one way. If the plug won't go into the outlet completely, turn the plug over and try to insert it the other way. If it still won't fit, contact a qualified electrician to change the outlet, or use a different one. **Do not attempt to bypass this safety feature.**

FOR YOUR RECORDS

In the event that service should be required, you may need both the Model number and the serial number. In the space below, record the date and place of purchase, and the serial number:



Model No. RP-7983B/RP-7984A

Date of Purchase _____

Place of Purchase _____

Serial No. _____

WARNING: TO PREVENT FIRE OR ELECTRICAL SHOCK HAZARD, DO NOT EXPOSE THIS PRODUCT TO RAIN OR MOISTURE.

 THE LIGHTNING FLASH AND ARROW HEAD WITHIN THE TRIANGLE IS A WARNING SIGN ALERTING YOU OF "DANGEROUS VOLTAGE" INSIDE THE PRODUCT.	CAUTION RISK OF ELECTRIC SHOCK DO NOT OPEN CAUTION: TO REDUCE THE RISK OF ELECTRIC SHOCK, DO NOT REMOVE COVER (OR BACK). NO USER-SERVICEABLE PARTS INSIDE. REFER SERVICING TO QUALIFIED SERVICE PERSONNEL.	 THE EXCLAMATION POINT WITHIN THE TRIANGLE IS A WARNING SIGN ALERTING YOU OF IMPORTANT INSTRUCTIONS ACCOMPANYING THE PRODUCT.
SEE MARKING ON BOTTOM / BACK OF PRODUCT		

WHERE TO START

Owning an RCA portable stereo system is like having a component stereo that you can take with you just about anywhere, giving you flexibility and convenience (not to mention great sound).

LOOKING FOR A GOOD READ?

You won't find this instruction book on the best seller list, but it does contain a lot of information that you should know before using your portable stereo.

I know that you want to *use* your stereo, not *read about it*, but you really should read the section, "First Things First," to make sure you get it hooked up correctly; then, as you have time, you can read about all of the great features of this stereo.

If you have any questions, be sure to check the Troubleshooting Tips section, the Index, or the Table of Contents to help you find the answer.

Two Products One User's Guide

RP-7983 – no remote

RP-7984 – with remote

This instruction book covers two different models. Please note the model number of your unit; the RP-7984 has a remote control and the RP-7983 doesn't have one. If you have a remote control, please read the Remote Control section on page 11.

TABLE OF CONTENTS

FIRST THINGS FIRST	2
POWERING UP	2
SPEAKER HOOKUP	2
HEADPHONES	3
ANTENNAS	3
GENERAL CONTROLS	3
THE DISPLAY	4
USING THE RADIO	5
USING THE CD PLAYER	6
LOADING AND PLAYING DISCS	7
SHUFFLING PLAY ORDER	7
REPEATING PLAY ORDER	7
PROGRAMMING PLAY ORDER	8
USING THE CASSETTE DECK	9
PLAYING CASSETTE TAPES	9
RECORDING ON CASSETTE TAPES	10
THE REMOTE CONTROL (RP-7984 ONLY)	11
CARE AND MAINTENANCE	13
TROUBLESHOOTING TIPS	14
INDEX	15
WARRANTY	16

FIRST THINGS FIRST

Before you start, you need to know a couple of things.

POWERING UP

This portable stereo operates on battery or AC power.

BATTERY POWER

Insert 8 D-sized alkaline batteries into the battery compartment as shown the back of the main unit, and you can take your stereo just about anywhere.

AC POWER

Plug the power supply cord into the AC power jack on the back of the unit and into an AC power outlet that accepts the polarized plug (one blade wider than the other).

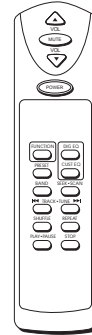
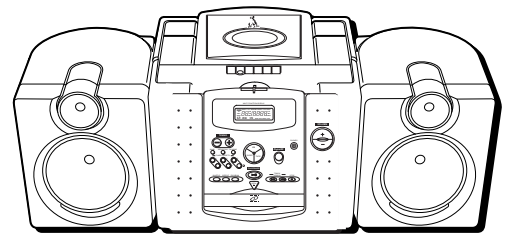

Remote Control
RP-7984 ONLY

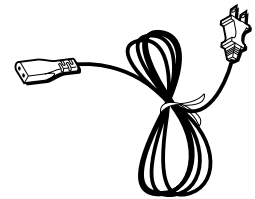

AC power supply cord

SPEAKER HOOKUP

To speaker terminals on main cabinet back:

1. Press down on the tab to open the red terminal and insert the red wire (+) into the terminal.
2. Press down on the tab to open the black terminal and insert the black wire (-) into the terminal.
3. Ensure left speaker wires are connected to left speaker terminal and right speaker wires are connected to right speaker terminal.

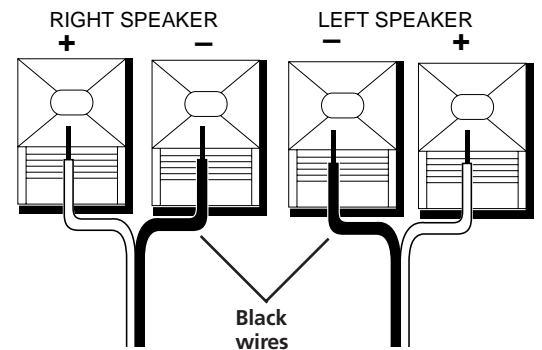

DETACHING THE SPEAKERS FROM MAIN UNIT

1. Disconnect the speaker wires from the main cabinet terminals.
2. Press on the tab securing the speaker to the base unit and then slide the speaker up until it comes off of the unit.
3. Reattach the speaker wires to main cabinet speaker terminal as described in "Speaker Hookup."

ATTACHING SPEAKERS TO THE MAIN CABINET

1. Slide the speaker down the side rail on cabinet side.
2. Speaker release tab locks in place.

WARNING:

Be sure to follow the speaker hookup instructions carefully; the system can be damaged if speakers are improperly connected.

HEADPHONES

To listen to your stereo with headphones (not included), use the 3.5 mm PHONES jack on the front of the unit. Make sure that you turn down the volume before you put on the headphones; then increase the volume to the desired level after they are in place.

ANTENNAS

Since the AM antenna is built in; adjusting the position of the unit may help AM reception.

The FM whip antenna on the back of the unit can be extended and rotated for better FM reception.

GENERAL CONTROLS

You've chosen a power source and hooked up the speakers. Now you need to know about the buttons and controls that are common to all components of the stereo: the radio, tape deck and CD player.

POWER BUTTON

Press the POWER button to turn on the unit (the POWER light on the front of the unit comes on). The display activates and the system begins operating from the last sound source used—the radio, the tape deck, or the CD player.

FUNCTION CONTROL

Press the Function Control to choose the function you want to use: RADIO, DISC, or TAPE. Your selection is reflected in the display.

VOLUME

Press VOLUME + (up) or – (down) to increase or decrease the volume level.

PRESET DIGITAL EQ

The Digital EQ button controls the preset equalizer settings. The display always shows the current preset EQ setting. Keep pressing and releasing the Digital EQ button until the preset setting you want (ROCK, JAZZ, VOCAL, or FLAT) appears in the display.

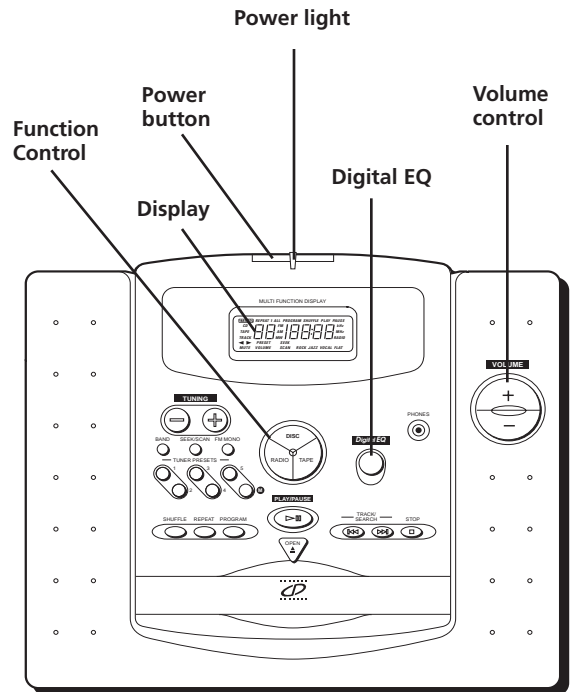

THE LIQUID CRYSTAL DISPLAY

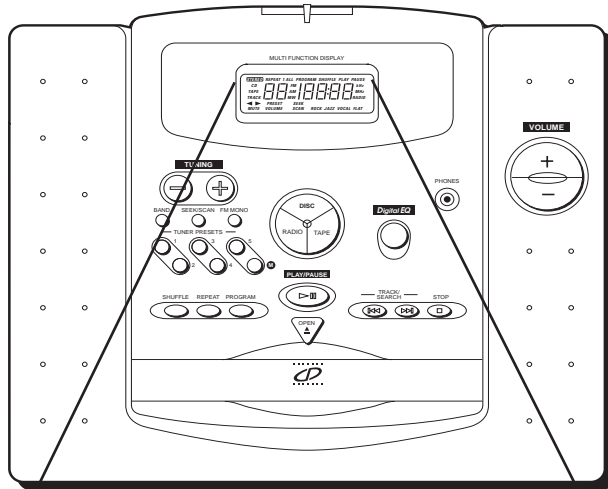

Don't Worry...It Won't Bite

So you think the display looks intimidating. Don't worry, you won't see all of this stuff at the same time—you'll only see what you need to see.

Note: the display is back lit for model RP-7984 only.

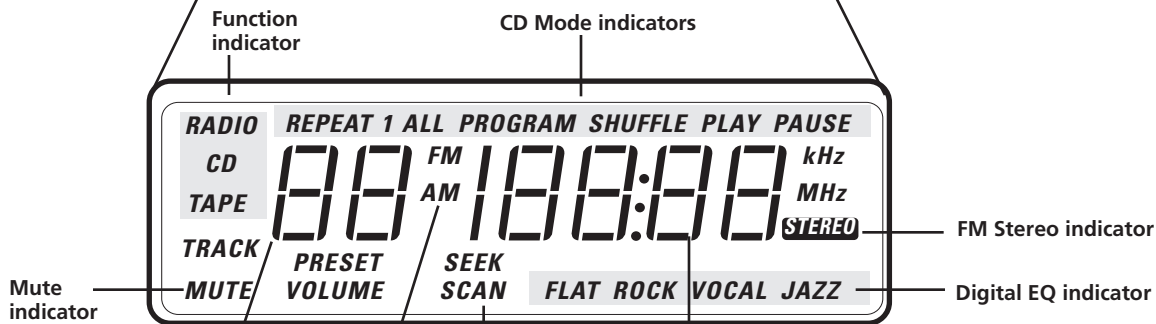

- Number indicator for:
- Preset radio stations
 - Track
 - Volume level
 - Custom EQ level (RP-7984). See page 12.

- Tuner indicator:
- Radio station
 - CD playing time
 - Display Messages
 - Custom EQ band (RP-7984). See page 12.

The following list of display information is presented in alphabetical order and corresponds to the items in the preceding graphic.

CD Mode Indicators: Show the current CD function mode.

Digital EQ Indicator: Shows which preset option you have chosen (ROCK, JAZZ, VOCAL, or FLAT).

FM Stereo Indicator: Displayed when you are receiving stations in FM Stereo mode. (The station must be broadcasting in stereo as well.)

Function Indicator: Shows the current function (RADIO, DISC, or TAPE).

Mute: Displayed when you press MUTE on remote control (RP-7984 only) or when you set volume control on the unit to 00 position.

Number Indicator: Depending on the current mode, shows the preset number for radio stations, the track number of a CD, or displays the volume setting when adjusting the volume or custom EQ levels (RP-7984 only).

Radio Band Indicator: Shows the current radio band.

SEEK/SCAN Indicator: SEEK or SCAN is displayed depending on which method of radio tuning you are using.

Tuner Indicator: Shows information such as radio station frequency, CD playing time, and display messages.

USING THE RADIO

Not only does the digital tuner help you tune in radio stations more easily, it also lets you preset as many as five AM and five FM radio stations for easy access.

TUNING IN RADIO STATIONS

After you choose the radio feature by pressing RADIO on the Function Control, you can do the following:

- Press the BAND button to change the radio band to AM or FM.
- Press the TUNING buttons to change the radio station.
- To turn on the **Seek** feature, which locates the next station, press and quickly release the SEEK/SCAN button.
- To turn on the **Scan feature** which searches for stations, press and momentarily hold the SEEK/SCAN button before releasing it. When a station is found, the Scan feature allows you to listen for a few seconds and then moves to the next station. When you find a station you like, press the SEEK/SCAN button again to choose that station.
- Press the FM/MONO button to listen to FM stations in either mono or stereo (STEREO appears in the display when listening to FM stereo).

Note that AM stations are broadcast in mono only and that the FM radio station must be transmitting in stereo for you to receive it in stereo.

STORING RADIO STATIONS IN MEMORY

Preset up to five AM and five FM stations for easy access.

1. Choose the radio band and station.
2. Press **M** (the Memory Preset button). The PRESET indicator and the station frequency blink in the display.
3. Press one of the five TUNER PRESETS buttons to store the radio station frequency in that preset location.

RECALLING PRESET STATIONS

1. Choose the radio band (AM or FM).
2. Press the appropriate TUNER PRESETS button (the PRESET number appears in the display).

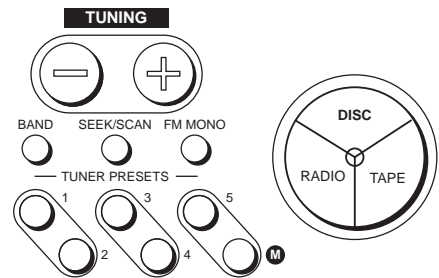
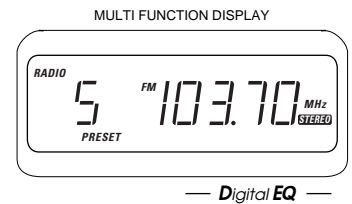

Playing Hide and Seek

Sometimes the Seek and Scan features might not locate an available station because the signal is not strong enough. If you know the frequency of the station you're looking for, you might want to use the TUNING buttons instead.

Weak Reception?

If the reception of an FM station transmitting in stereo is weak, the STEREO indicator might fade in and out. Adjusting the FM whip antenna can help. If not, changing from FM Stereo to FM Mono might improve reception (just remember that you'll no longer be listening in stereo).

USING THE CD PLAYER

Combined with features such as Shuffle, Repeat, and Programmed play, you have lots of options for playing CDs.

KNOWING YOUR BUTTONS

The following buttons are used for basic CD operation:

PLAY/PAUSE  — This button works as a toggle switch: press to begin play, press again to pause play.

TRACK/SEARCH  and 

- In **Stop mode**— Press to move to the beginning of the preceding or following track.
- In **Play or Pause mode** — Press and release to move to the beginning of the preceding or following track. Press and hold to search within a track.

STOP  — Press to stop play.

Look for this Logo

You can play 3" and 5" compact discs that have this logo.

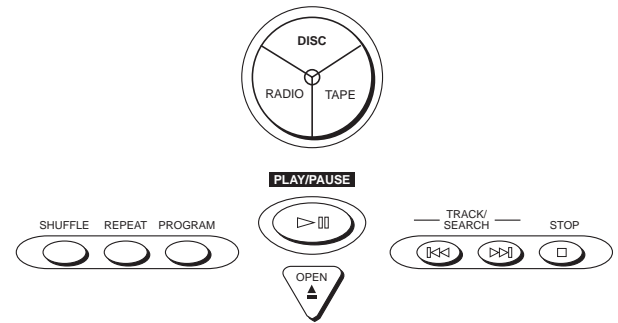

THE DISPLAY





When the power is on, the display tells you what's going on with your system. (See "Display" section, page 4)

CD DISPLAY MESSAGES

The following messages appear in the display to tell you what the CD player is doing:

Message	Meaning
<i>cd</i>	DISC (CD) function is active. (Note: <i>cd</i> is an icon)
<i>dr in</i>	CD drawer is in (closed).
<i>dr out</i>	CD drawer is out (open).
<i>no disc</i>	No disc is in the tray or the disc is damaged or unreadable.
<i>-- Pr:01</i>	No tracks are programmed (applies to Program mode).
<i>Pr FULL</i>	Program is full (applies to Program mode). This is displayed for three seconds when the last track is programmed.
<i>Pr CLR</i>	Program has been cleared (erased) from memory (applies to Program mode).
<i>rEAd</i>	Reading CD's table of contents (how many tracks it has and the total time for the disc). This information is displayed in Stop mode.

LOADING AND PLAYING CDs

1. Select the CD function by pressing DISC on the Function Control.
2. Press the OPEN  button to open the CD drawer.
3. Place a CD into the tray with the label facing up.
4. Press the OPEN  button again to close the CD drawer.
5. Press PLAY/PAUSE  to begin play.
6. Press STOP  to stop disc play.

The current track number and the elapsed time of the track appear in the display while the track is playing.

SHUFFLING PLAY ORDER

Turning on the Shuffle feature causes the tracks to play in a random order.

- Press the SHUFFLE button to start random track play. (The Shuffle mode indicator appears in the display while the feature is active.)
- Press the SHUFFLE button a second time to turn off the feature.

REPEATING PLAY ORDER

Use the REPEAT button to repeat one track or an entire CD.

- Press the REPEAT button once to repeat the current track (**REPEAT 1** appears in the display).
- Press REPEAT a second time to repeat all tracks (**REPEAT ALL** appears in the display).
- Press REPEAT a third time to turn off the feature.

In Shuffle mode:

- Press the REPEAT button once to repeat the current track (**REPEAT 1** appears in the display).
- Press REPEAT a second time to repeat all tracks in a different shuffle order (**REPEAT ALL** appears in the display).
- Press REPEAT a third time to turn off the feature.

In Program mode:

- Press the REPEAT button once to repeat the current track (**REPEAT 1** appears in the display).
- Press REPEAT a second time to repeat the program (**REPEAT ALL** appears in the display).
- Press REPEAT a third time to turn off the feature.

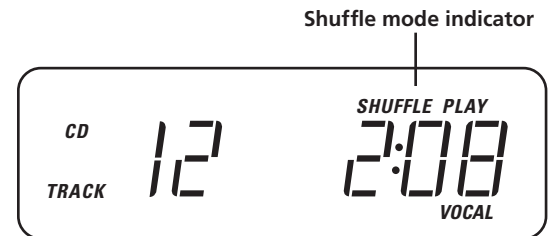
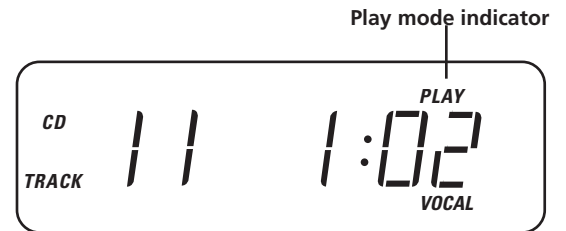

You Can't Shuffle a Program

The Shuffle feature is not available during Program mode. If you press SHUFFLE while in Program mode, the CD player will exit the program and start "shuffling" (playing tracks in random order).

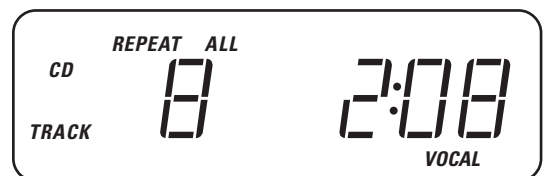
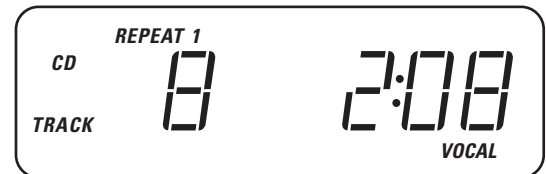

PROGRAMMING PLAY ORDER

1. Press the PROGRAM button to enter Program mode.
 - -- Pr:01 appears in the display indicating that this is the first programmed track.
2. Press TRACK/SEARCH ◀◀ or ▶▶ to choose a track. (**PROGRAM** begins flashing in the display.)
3. Press PROGRAM to save the track in the program memory. (**PROGRAM** stops flashing in the display.)
4. Repeat steps 2-4 above to program up to 20 tracks.
 - Pr Full appears in the display for three seconds when the program is full; then the first program is displayed.
5. Press PLAY/PAUSE ▶|| to begin programmed play.
6. To stop playing the current programmed track, press STOP ■ once.
7. To delete a program, press and hold the PROGRAM button until Pr CLr appears in the display. This deletes the program, but does not exit you from program mode.
8. To exit program mode, press STOP ■ twice.

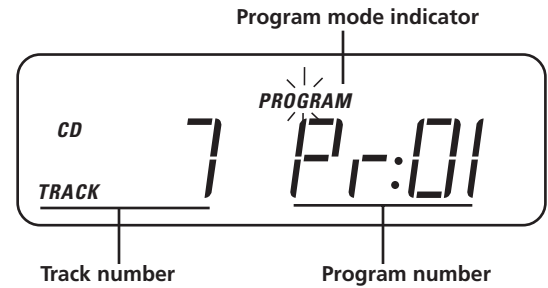

What's Program Mode?

Pressing the PROGRAM button puts you into Program mode (**PROGRAM** appears at the top of the display). In this mode, you can program tracks, edit the program, or you can play tracks you've already programmed.

EDITING THE PROGRAM

To edit a program, the unit must be stopped and in Program mode.

1. Press PROGRAM to move to the next program number until you get to the programmed track you want to change (Track 7, Program 01 in the example to the right).
2. Press TRACK/SEARCH ◀◀ or ▶▶ to choose a track (Track 10 in the example to the right)
3. Press PROGRAM to change the current programmed track to the one you just selected. (Track 7 is changed to track 10 in the example to the right.)

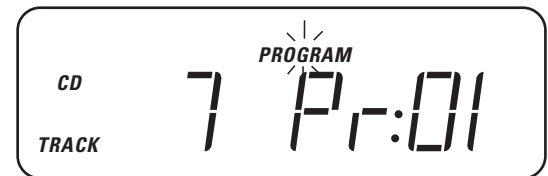

Track 7 is the first programmed track

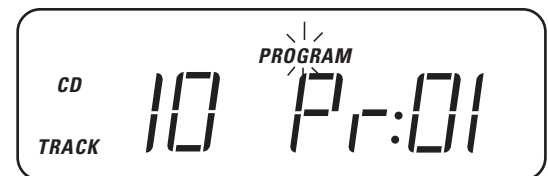

Track 10 replaces Track 7 as the first programmed track.

CLEARING THE PROGRAM

To clear the program from memory, press and hold the PROGRAM button. Pr CLr appears in the display.

Note: The program will also be cleared from memory if you turn off the unit or press OPEN ▲ to open the CD drawer.

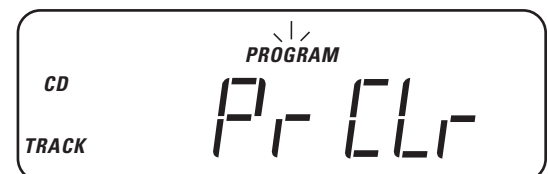

You can clear a program from memory by pressing and holding the PROGRAM button until Pr CLr appears in the display.

USING THE CASSETTE TAPE PLAYER

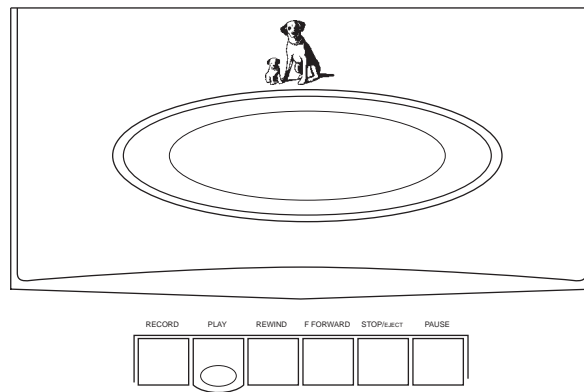

UNDERSTANDING THE BUTTONS

If you know what each button does, it's easy to figure out how to operate the tape deck.

RECORD — Press to record from the radio or the CD player.

PLAY — Press to play a cassette.

REWIND — From stop mode, press to rewind the tape toward the beginning.

F. FORWARD — From stop mode, press to advance the tape toward the end.

STOP/EJECT — Press to stop current tape activity, or to open the cassette compartment door when no buttons are active.

PAUSE — Press to interrupt tape play or record mode. Press a second time to resume tape play or tape record mode.

PLAYING CASSETTE TAPES

1. Press **TAPE** on the Function Control.
2. Press **STOP/EJECT** to open the cassette compartment door.
3. Insert a cassette tape into the door with the top of the tape going in first.
4. Close the door securely.
5. Press **REWIND** or **F. FORWARD** to move tape to the desired starting point.
6. Press **PLAY** to begin playing the tape.

RECORDING ON CASSETTE TAPES

You can record programs from the radio or the CD player. Just set up the system to use whichever option you choose, and then record it. For best results, use normal bias cassette tapes.

RECORDING FROM THE RADIO

1. Insert a cassette tape into the tape deck.
2. Choose the RADIO function and select a radio station.
3. Press the RECORD button to begin recording.
4. Press STOP/EJECT to end recording.

RECORDING FROM THE CD PLAYER

1. Insert a cassette tape into the tape deck.
2. Choose the DISC function.
3. Insert the CD you want to record. You can start with any track on a disc (or you can create a program to record).
4. Press PLAY/PAUSE ►|| on the CD player twice (to begin and pause disc play).
5. Press the RECORD button on the cassette deck to begin recording.
6. Press PLAY/PAUSE ►|| on the CD player.

ERASE PROTECTION

When you record new material, the cassette deck records over whatever is on a tape. To protect a tape from accidental erasure, break off one or both plastic tabs (one for each tape side) on the top of the cassette tape. If you decide later to record on the tape, seal the hole with a piece of cellophane tape.

Pause for a Moment

Using the PAUSE || button on the cassette deck instead of the STOP button to momentarily interrupt recording gives you a much cleaner sounding recording when you play it back later.

Quit Slacking

A little bit of slack in your tapes can cause scratches on the tape, or worse yet, the tape could break. If you notice some slack in the tape, use a pencil to tighten it up before you insert it.

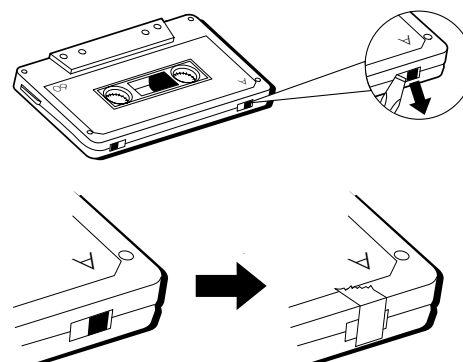
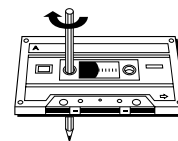

We're on the Level

The built-in Automatic Level Control automatically sets the input level for optimum recording sound. You can listen to, and even adjust the volume setting without affecting the quality of the recording.

USING THE REMOTE CONTROL (MODEL RP-7984 ONLY)

INSTALLING BATTERIES

1. Slide the battery cover in the direction of the arrow and lift.
2. Install 2 "AAA" batteries (not included). Face batteries in the direction indicated on the back.
3. Slide the cover firmly back into place.

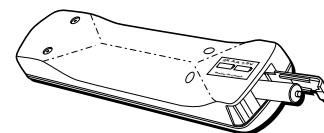
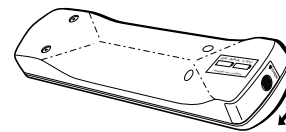

THE BUTTONS

Your remote control operates many of your portable stereo's features. All of the buttons on the remote (except the volume and stop buttons) are used to "toggle" through a list of selections. For example, the POWER button toggles between on and off. Press POWER once and the unit turns on, press it again and the unit turns off. If you're confused, check the display to see what "toggle" you're in!

POWER: Turns unit on and off.

VOL (Volume up and down buttons): Control sound level.

MUTE: Suspends the output of sound (press MUTE again to restore sound).

FUNCTION: Selects RADIO, DISC, or TAPE.

DIG EQ: (Digital Equalizer): Selects preset equalizer settings (JAZZ, ROCK, VOCAL, or FLAT).

CUST EQ (Customized Equalizer): Press to create and use a personalized equalizer setting. See "Custom EQ Setting" on the next page to learn how to use this feature.

BAND (RADIO function): Selects AM and FM.

PRESET (RADIO function): Selects preset radio stations (five stations for AM and five stations for FM).

SEEK•SCAN (RADIO function): Press and release to activate the **Seek feature**. Press and momentarily hold to activate the **Scan feature** which searches for stations continually. When using **Scan feature**, press the button again to choose that station.

TRACK•TUNE forward and reverse buttons (RADIO and DISC function): Serve as Track/Search (forward and reverse) controls in CD mode. Serve as Tuning up and down controls in RADIO mode.

SHUFFLE (DISC function): Activates Shuffle mode.

REPEAT (DISC function): Selects Repeat 1 when you press once or Repeat All when you press it twice (press a third time to turn off Repeat feature).

PLAY•PAUSE: Plays CD and pauses play of the CD.

STOP (DISC function): Stops play.

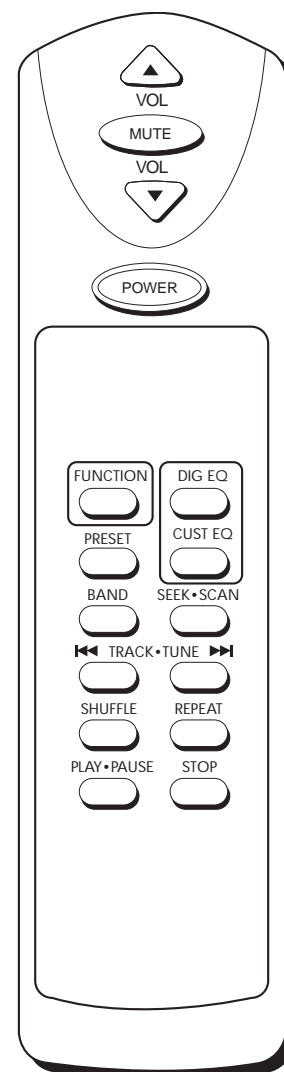

CUSTOM EQ SETTING (RP-7984 ONLY)

The Custom EQ feature enables the listener to keep a personalized electronic equalizer setting in memory. To create your Custom EQ setting you must use the remote control.

1. Press CUST EQ button on the remote. **USER** appears in the display. All preset EQ icons turn off.
2. Press CUST EQ again. The first band **200** (bass) appears in the display.
3. Press the VOL (volume) up and down buttons to adjust the level.
4. Press CUST EQ when you're satisfied with the setting for first band and the second band **2.0 KHz** (mid) appears in the display.
5. Press the VOL (volume) up and down buttons to adjust the level.
6. Press CUST EQ when you're satisfied with the setting for second band and the third band **10.0 KHz** (treble) appears in the display.
7. Press the VOL (volume) up and down buttons to adjust the level.
8. When you're finished creating your customized setting, your portable stereo will automatically save the setting and the display will return to its previous state after several seconds.

To select your Custom EQ setting, you must use the remote control.

1. Press CUST EQ on the remote. **USER** appears in the display.

NOTE: Once you are in Custom Equalizer mode, pressing CUST EQ scrolls through the three equalizer bands (USER does not appear in display). You can adjust any one of them with the volume buttons. To use one of the preset equalizer selections, press DIG EQ on the remote or the Digital EQ button on the unit.



HEADPHONE SAFETY

For your **comfort, health and safety**, be sure to observe the following guidelines when using headphones:

Hearing Comfort & Well Being

- Always turn volume down to the minimum setting before plugging in the headphones.
- Don't listen at a high volume.
- Hearing experts advise against extended continuous listening through a headset.
- If you experience a ringing in your ears, reduce volume or discontinue use.

Safety

- Don't use headphones while operating a motorized vehicle. This can create a traffic hazard and is illegal in many areas.
- Do not use headphones in potentially hazardous situations.
- Even if your headset is an open-air type designed to let you hear outside sounds, don't turn up the volume so high that you can't hear what's around you.

CARE AND MAINTENANCE

CLEANING THE EXTERIOR

- Disconnect the system from AC power before cleaning the exterior of the unit with a soft dust cloth.

HANDLING COMPACT DISCS

- Do not touch the signal surfaces. Hold by the edges, or by one edge and the hole.
- Do not affix labels or adhesive tape to the label surfaces. Also, do not scratch or damage the label.
- Discs rotate at high speeds inside the player. Do not use damaged (cracked or warped) discs.

CLEANING COMPACT DISCS

- Dirty discs can cause poor sound quality. Always keep discs clean by wiping them gently with a soft cloth from the inner edge toward the outer perimeter.
- If a disc becomes dirty, wet a soft cloth in water, wring it out well, wipe the dirt away gently, and then remove any water drops with a dry cloth.
- Do not use record cleaning sprays or anti-static agents on discs. Also, never clean discs with benzene, thinner, or other volatile solvents which may cause damage to the disc surface.

TAPE CARE

- Don't expose tapes to sunlight or store in hot places. High temperatures may warp the shell or damage the tape itself.
- Keep cassettes in their boxes when not in use.
- Cassette tapes can be erased by magnetic fields produced by magnets, electric motors, electrical transformers, and other devices. Keep tapes away from magnets and magnetic fields.

CLEANING THE TAPE HEADS

Iron oxide particles from the magnetic tape can build up on the parts that come in contact with the tape. These deposits can cause incomplete erasure, muffled playback sound, and might prevent automatic stop.

Always unplug the power cord before cleaning, and allow 30 minutes drying time when using a liquid cleaner. Clean the heads after every 25 hours of use.

To clean the cassette tape player, open the compartment door, push the PLAY button and gently clean the heads, capstan, and pinch wheel with a head cleaner.

- Demagnetize the head occasionally with a head demagnetizing cassette (available from many audio equipment stores).
- Never use any metal objects on or near the tape heads. Do not allow any cleaning material to fall into the tape assembly.

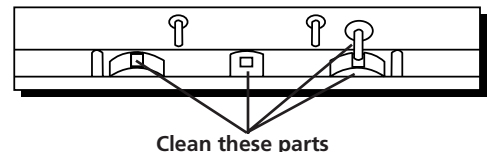

TROUBLESHOOTING TIPS

<i>Problem</i>	<i>Solution</i>
System doesn't turn on	<ul style="list-style-type: none">• Make sure power cord is securely plugged into the AC power outlet (or that the batteries are fresh).• When operating on batteries, make sure the AC power cord is unplugged from the AC power jack on the back of the main unit.• Unplug the unit for a moment, and then plug it back in.• Check the outlet by plugging in another device.
No sound	<ul style="list-style-type: none">• Adjust volume setting.• Press MUTE on the remote (Model RP-7984 only).• Check for proper connection of speaker wires.• Make sure you've selected the correct function: CD, TAPE, or RADIO
Poor radio reception	<ul style="list-style-type: none">• Adjust the FM whip antenna for better FM reception .• Rotate the unit to achieve better AM reception.• Try turning off electrical appliances near the unit, such as hair dryers, vacuum cleaners, or fluorescent lights.
CD doesn't play	<ul style="list-style-type: none">• Make sure the tray contains a disc.• Try another disc.• Make sure that disc's label is facing up.• Make sure that Pause mode is not activated.• Make sure DISC function is selected.
CD sound skips	<ul style="list-style-type: none">• Clean the disc (as explained in "Care and Maintenance").• Check disc for warping, scratches, or other damage.• Check for vibration or shock that may affect the unit; move system if necessary.
Distorted or noisy recordings	<ul style="list-style-type: none">• Inspect the recording head and clean it if necessary.• Demagnetize recording head (as explained in "Care and Maintenance").
Remote control won't work	<ul style="list-style-type: none">• Be sure the unit is plugged into a working AC outlet.• Press POWER button to assure that the system is on.• Press the FUNCTION button on the remote until desired function is selected: CD, TAPE, or RADIO.• Replace batteries if they are weak. Assure that batteries are installed in the directions indicated on the back of the remote.• Point the remote control directly at the remote sensor while pressing buttons.• Move closer to system while using the remote control.• Move any obstacles between the remote and the system.

INDEX

A

AC Power 2
Antenna 3

B

BAND button 5
Battery Power 2

C

Cassette deck 9
Cassette Deck Buttons
 FAST FORWARD 9
 PAUSE 9
 PLAY 9
 RECORD 9
 REWIND 9
 STOP/EJECT 9
CD Buttons
 PLAY/PAUSE ►|| 6
 SHUFFLE 7
 STOP ■ 6
 TRACK/SEARCH ◀◀ and ▶▶ 6

Cleaning the Tape Heads 13
Compact discs 3" and 5" 6
Custom EQ Setting 12

D

Digital EQ button 3
Digital EQ Indicator 4
Display 4, 6

E

Editing a program 8
Erase Protection 10

F

FM Stereo Indicator 4
FM/MONO button 5
Function Control 3
Function Indicator 4

H

Headphones 3

L

Loading and playing CDs 7

M-P

MEMORY button 5
POWER button 3
 Numeric Indicator 4
PLAY/PAUSE ►|| button 6
POWER button 3
PRESET buttons 5
PRESET indicator 5
PROGRAM button 8
Program edit 8
Programming play order 8

R

Radio Band Indicator 4
Radio station presets 5
Recording on Cassette Tapes 10
Remote control 11
REPEAT button 7
Repeating Play Order 7

S

Seek/Scan feature 5, 11
SEEK/SCAN button 5, 11
SEEK/SCAN Indicator 4
SHUFFLE button 7
Shuffling Play Order 7
Speakers
 connecting 2
 detaching 2
STOP button 6
Storing Radio Stations in Memory 5

T

TRACK/SEARCH button 6
Troubleshooting Guide 14
TUNING buttons 5
Tuning In Radio Stations 5
 changing radio bands 5
 tuning in stations 5

V

VOLUME control 3

LIMITED WARRANTY

What your warranty covers:

- Any defect in materials or workmanship.

For how long after your purchase:

- One year.

(The warranty for rental units begins with the first rental.)

What we will do:

- Provide you with a new, or at our option, a refurbished unit.
- The exchange unit is under warranty for the remainder of the original product's warranty period.

How to make a warranty claim:

- Properly pack your unit. Include any cables, etc., which were originally provided with the product. We recommend using the original carton and packing materials.
- Include in the package evidence of purchase date such as the bill of sale. Also print your name and address and a description of the defect. Send standard UPS or its equivalent to:

Thomson Consumer Electronics, Inc.

Product Exchange Center

32 Spur Drive

El Paso, Texas 79906

- Pay any charges billed to you by the Exchange Center for service not covered by the warranty.
- A new or refurbished unit will be shipped to you prepaid freight.

What your warranty does not cover:

- Customer instruction. (Your Owner's Manual provides information regarding operating instructions and user controls. For additional information, ask your dealer.)
- Installation and set-up service adjustments.
- Batteries.
- Damage from misuse or neglect.
- Products which have been modified or incorporated into other products.
- Products purchased or serviced outside the USA.
- Acts of God, such as but not limited to lightning damage.

Product Registration:

- Please complete and mail the Product Registration Card packed with your unit. It will make it easier to contact you should it ever be necessary. The return of the card is not required for warranty coverage.

How state law relates to this warranty:

- This warranty gives you specific legal rights, and you may have other rights which vary from state to state.

If you purchased your product outside the USA:

- This warranty does not apply. Contact your dealer for warranty information.